



COLUMBIA COUNTY WASHINGTON

PLANNING & BUILDING DEPARTMENT

114 S. Second St., Dayton, WA 99328

Phone: (509) 382-4676

Technical Information

POLE BUILDINGS

The following is a typical cross-section for a residential/agricultural 'pole building'. It may or may not represent the proposed project. If you are referring to this detail as a portion of your plan submittal, please complete the requested information where indicated. This completed detail, along with any additional information, needs to be submitted with your application and be on site at the time of inspection.

Illustration 1

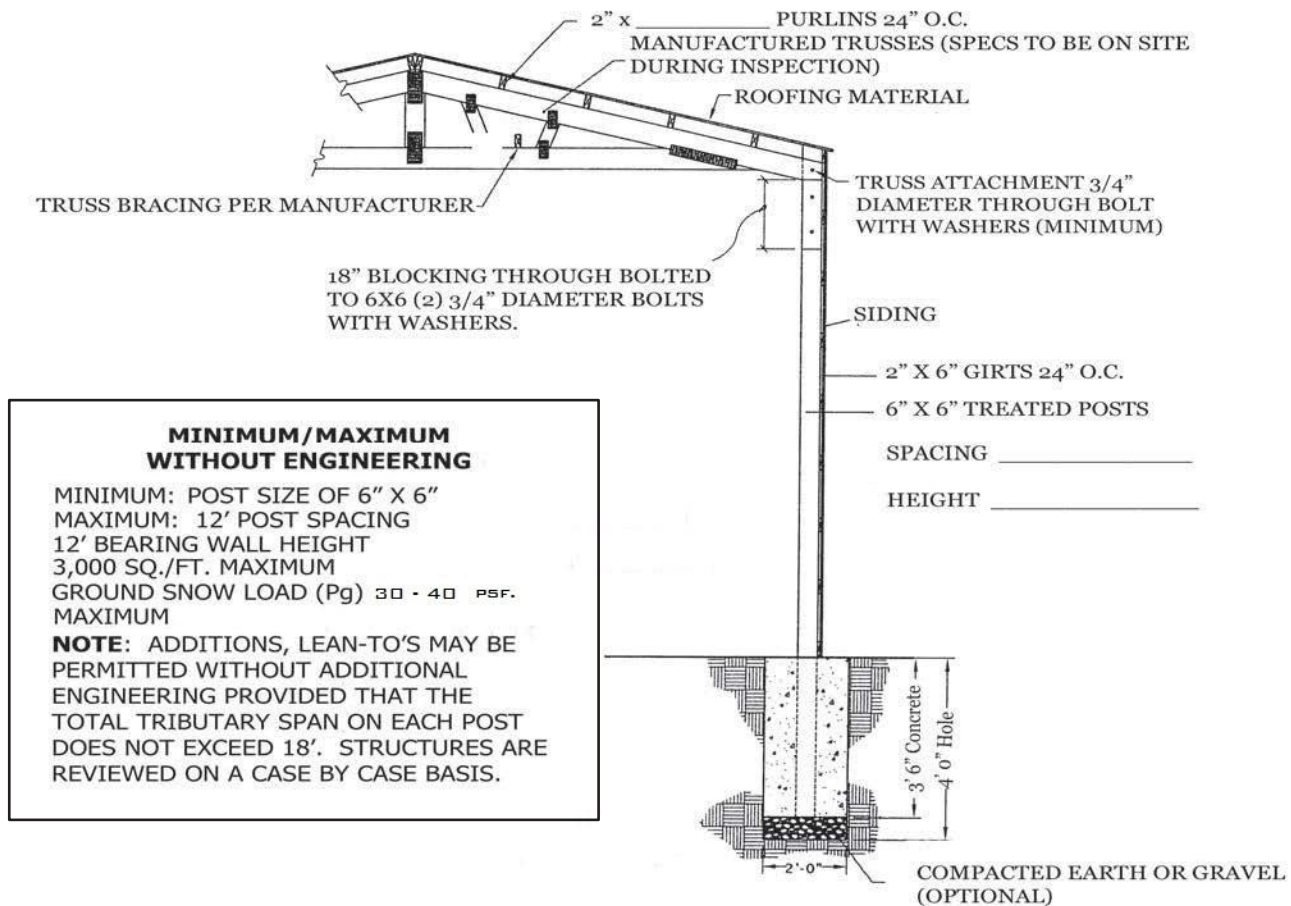
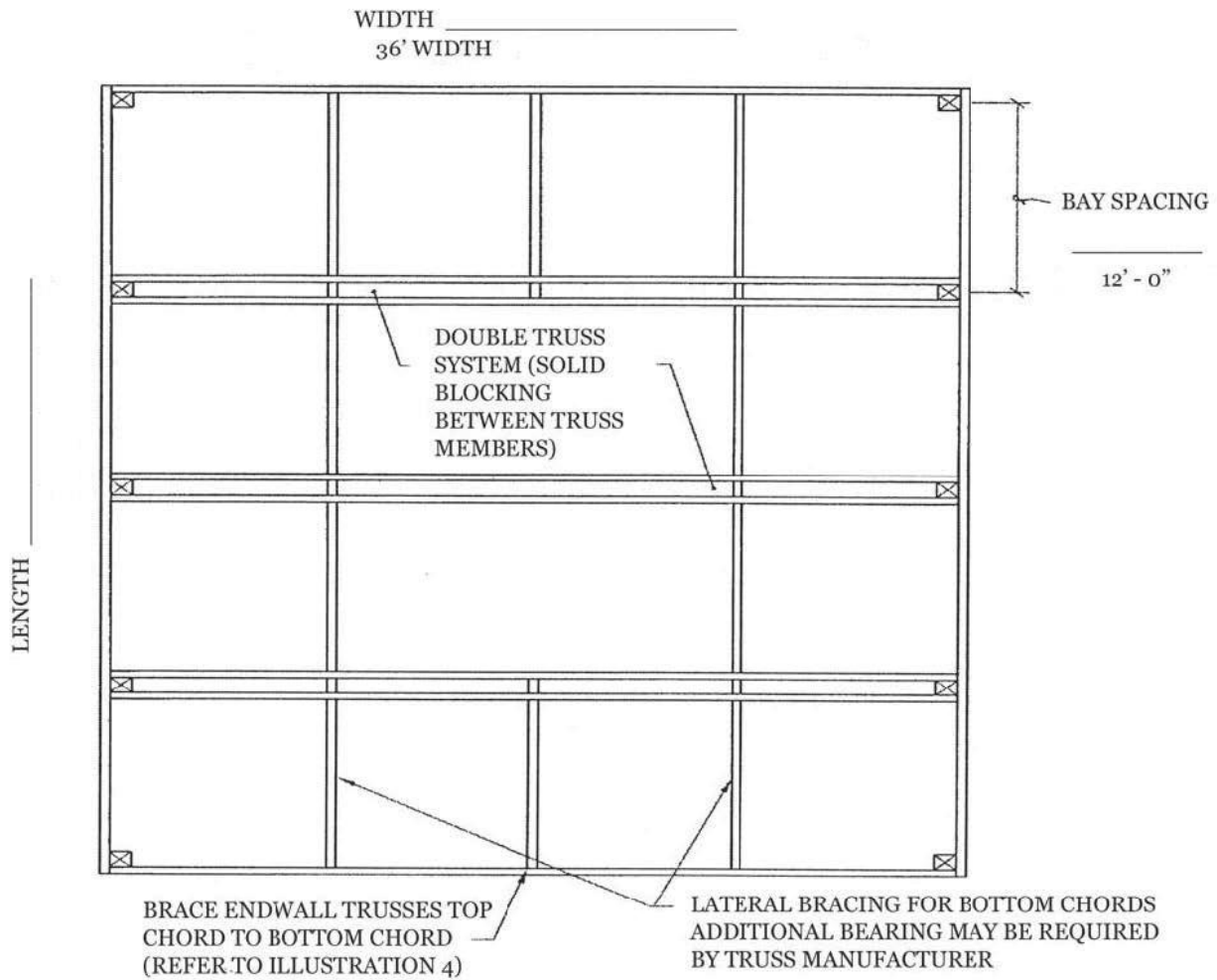

Illustration 2



Pole Building Foundation Detail Sample

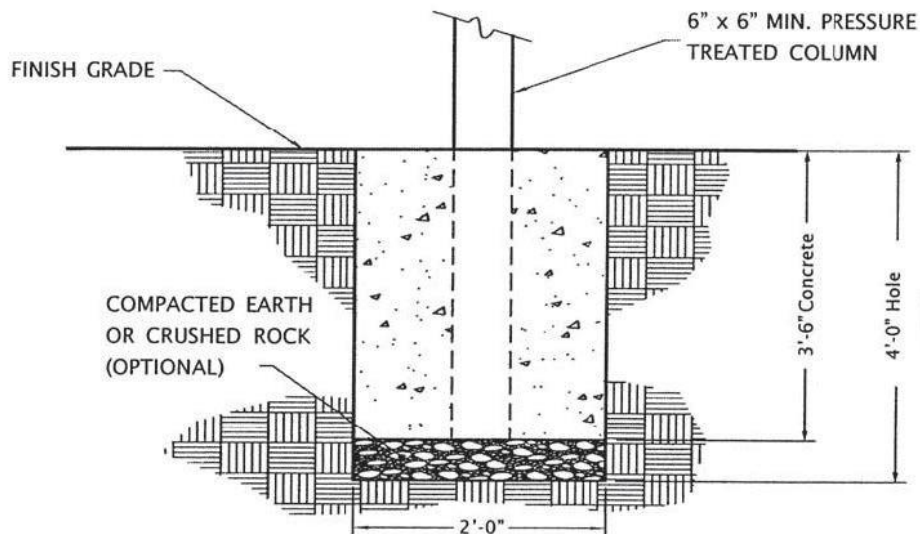
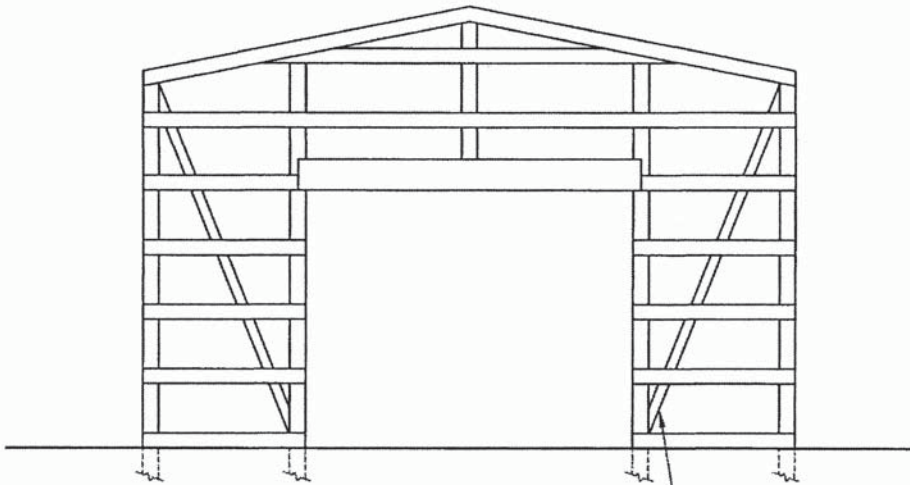
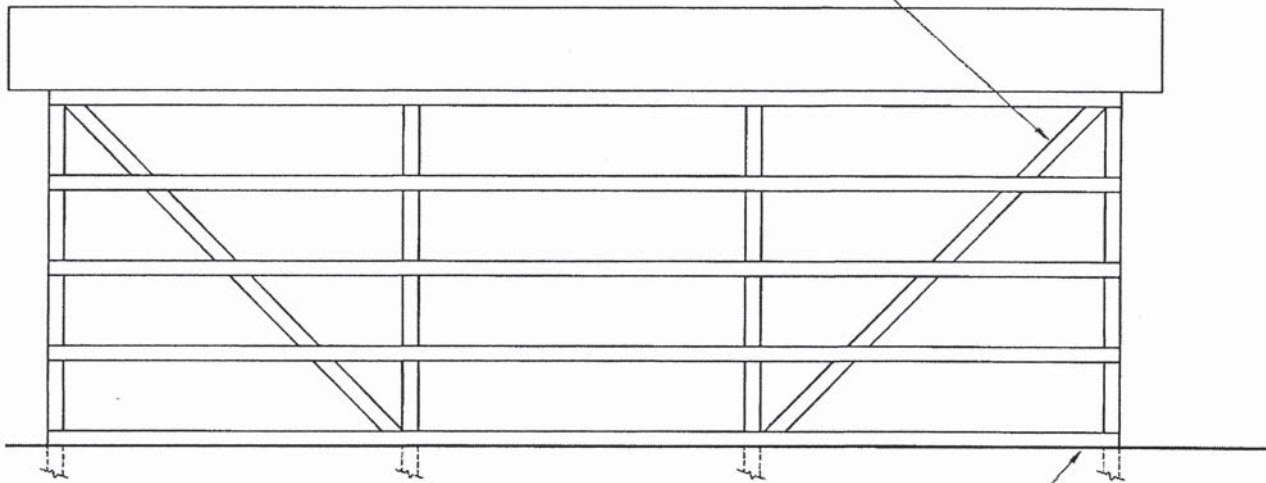

Illustration 3



2X4 (OR EQUIVALENT) BRACING EVERY 25 LINEAL FEET AND ALL CORNERS NAILED TO EACH GIRT WITH TWO (2) 10d NAILS



NATURALLY DURABLE WOOD OR PRESSURE TREATED BOTTOM GIRT

TYPICAL PURLIN CONNECTIONS

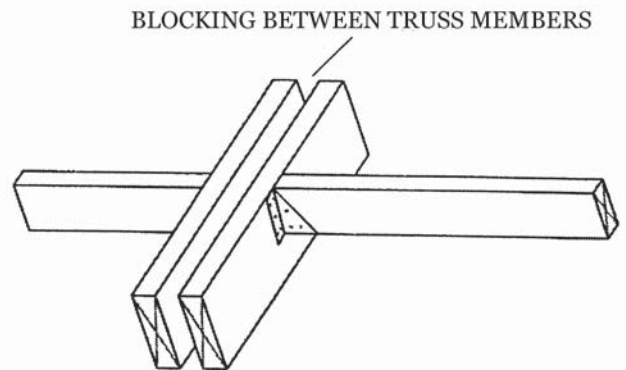
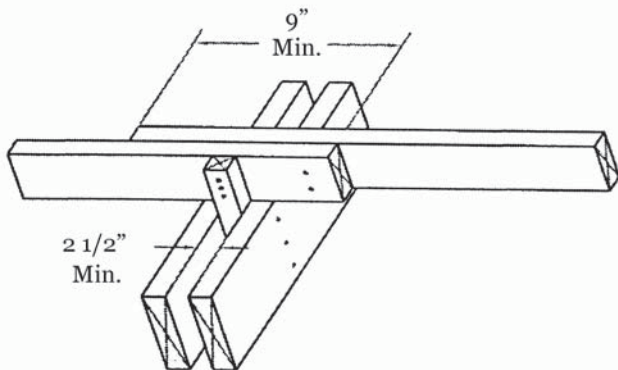
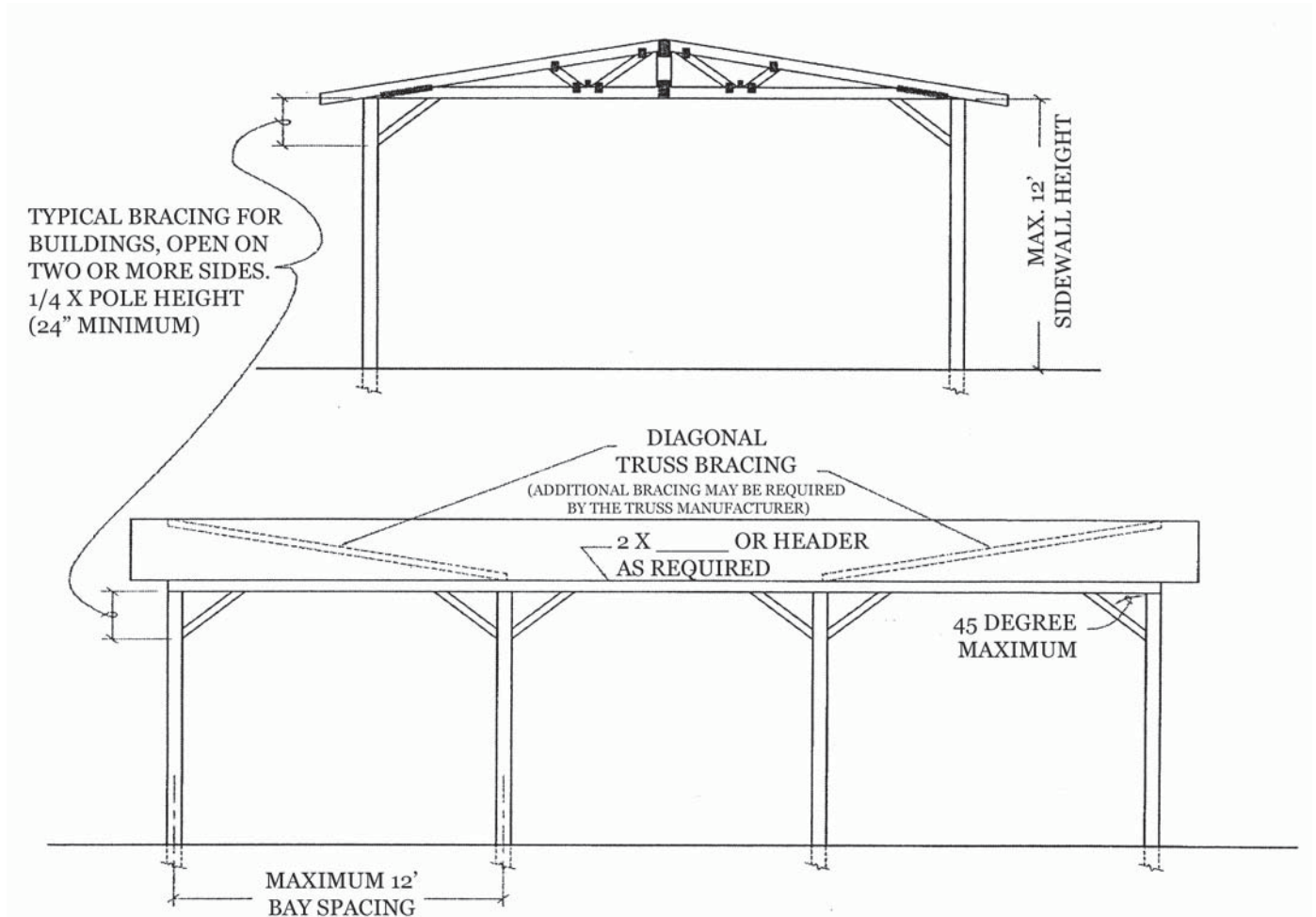

Illustration 4



REQUIRED INSPECTIONS:

1. Hole inspection required before holes are filled to determine diameter, depth of holes and set-backs of the structure relative to property lines.
2. Framing and Final inspection required after entire structure is framed and siding/roofing materials applied and **PRIOR** to use or occupancy of the building.

JURISDICTION CONTACT LIST:

- | | |
|---|----------------|
| <input type="checkbox"/> Building and Planning | (509) 382-4676 |
| <input type="checkbox"/> Public Works (Roads and Engineering) | (509) 382-2534 |

For more information contact:

Columbia County
Planning & Building Department
114 S. Second St.
Dayton, WA 99328
(509) 382-4676
www.columbiaco.com